



Series
BPX

SIZE 8 CONCENTRIC TWINAX SOCKET CONTACT
FOR S280W502-1 CABLE (AND PAN 6421 CABLE)
BOEING P/N: S280W552-205

Issue:
31/07/00

Page
1 / 1

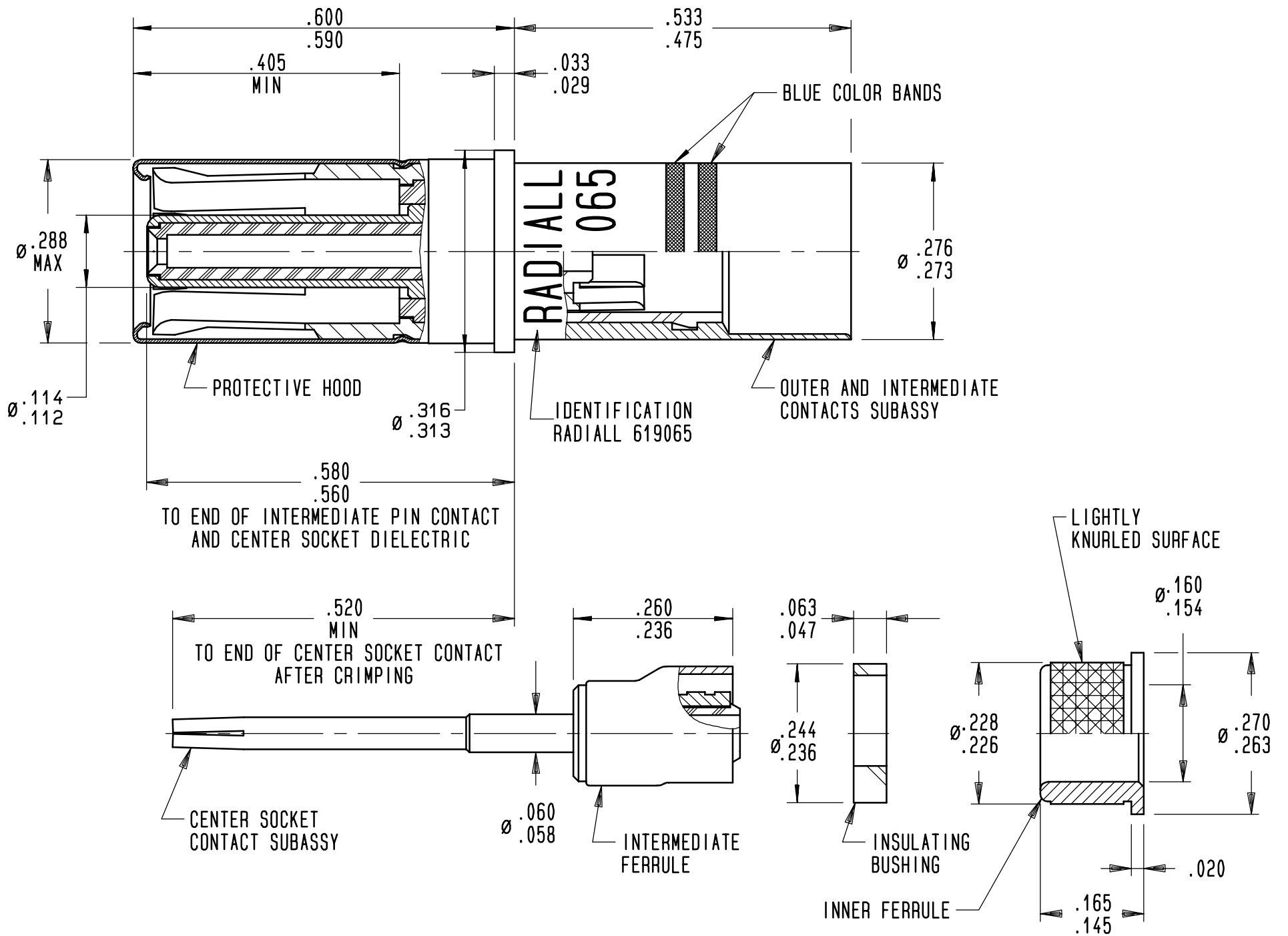

MATERIALS:

- PROTECTIVE HOOD: STAINLESS STEEL PER AISI 305
- OUTER AND CENTER CONTACT: BERYLLIUM COPPER ALLOY PER QQ_C_530 HEAT TREATED FOR SPRING TINES_ ANNEALED ON CRIMP BARREL
- INTERMEDIATE CONTACT: BERYLLIUM COPPER ALLOY PER QQ_C_530 HEAT TREATED
- FERRULE AND INNER FERRULE: BRASS PER QQ B 626
- INTERMEDIATE DIELECTRIC AND INSULATING BUSHING: TPFE
- CENTER DIELECTRIC: ULTEM

FINISHES (ALL METAL PARTS)

GOLD PLATE PER MIL_G_45204, TYPE II, GRADE C, CLASS 1 50 MICROINCHES OVER NICKEL PLATE PER QQ_N_290, CLASS 2

SEE WIRING INSTRUCTIONS: RP08820

This information is given as an indication. In the continual goal to improve our products, we reserve the right to make any modifications judged necessary.

4112-9610

CREATION				
PEN: .				
NOM: JP MACARI				
DATE: 29/04/94	31/07/00	ADD.PAN 6421 CABLE	GOMBERT	
APPR.: G.CARTESSE	20/11/97	REDRAWN-ADDED BLUE COLOR BAND	MACARI	JACOB
	Issue	Revisions	Name	Approved

RADIALL[®]

101, rue Philibert Hoffmann Z.I. Ouest
93116 ROSNY/BOIS Cedex (France)
Tl.: 01 49 35 35 35
Fax.: 01 48 54 63 63
Tlex: RADIA 235220